

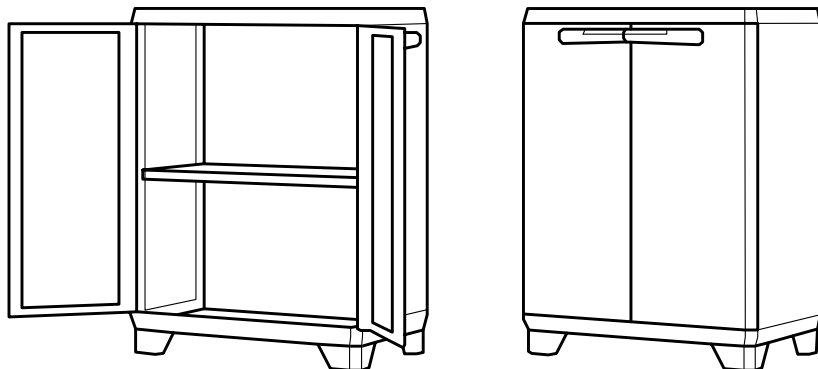











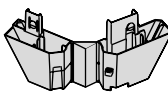
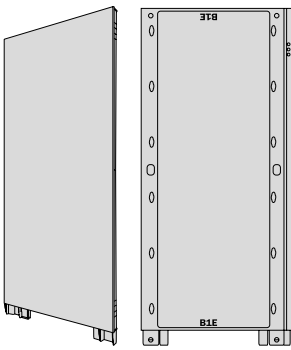
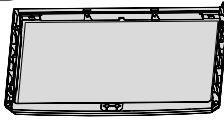
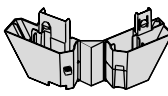
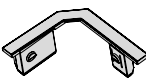

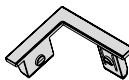
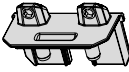
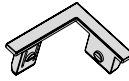

# LINEAR

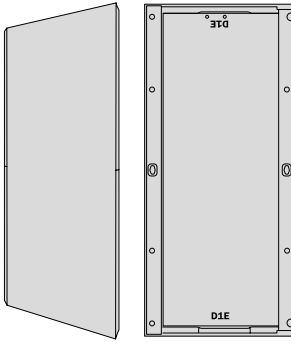
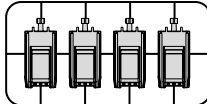
EN ASSEMBLY INSTRUCTIONS FR INSTRUCTIONS DE MONTAGE DE MONTAGEANLEITUNG NL MONTAGEVOOR-  
SCHRIFT ES INSTRUCCIONES DE MONTAJE IT ISTRUZIONI DI MONTAGGIO PT INSTRUÇÕES DE MONTAGEM  
EL ΟΔΗΓΙΕΣ ΣΥΝΑΡΜΟΛΟΓΗΣΗΣ



[WWW.KETER.COM](http://WWW.KETER.COM)

- EN IMPORTANT: Please contact Customer Service if you have any problems or discover any missing parts.
- FR IMPORTANT: Veuillez contacter notre Service Clientèle pour tout problème ou pièce manquante.
- DE WICHTIG: Bitte wenden Sie sich an unseren Kundenservice, falls Sie irgendwelche Probleme haben oder feststellen, daß Teile fehlen.
- ES IMPORTANTE: Sírvase contactar con nuestro Servicio al Cliente por cualquier problema, o pieza que pudiera faltar.
- IT IMPORTANTE: Si prega di contattare il Servizio Clienti per eventuali necessità.
- NL BELANGRIJK: Neemt u in geval van problemen of missende onderdelen a.u.b. contact op met de klantenservice.
- PT IMPORTANTE: favor entrar em contato com o Serviço ao Cliente se houver problemas ou se faltar peças.
- EL ΣΗΜΑΝΤΙΚΟ: παρακαλώ επικοινωνήστε με την Εξυπηρέτηση Πελατών αν αντιμετωπίσετε κάποιο πρόβλημα ή αν λείπει μέρος από την συσκευασία.

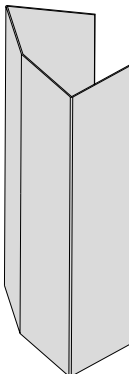
<p>1x E1E</p> 	<p>A2E</p> 	<p>2x B1E</p> 
<p>2x A/C1E</p> 	<p>A3E</p> 	
<p>C4E</p> 	<p>A4E</p> 	
<p>C5E</p> 	<p>A5E</p> 	
<p>C3E</p> 	<p>2x A/C3E</p> 	
<p>C2E</p> 	<p>2x</p> 	<p>2x D1E</p> 
<p>E2E</p> 	<p>2x</p> 	
<p>4x [4,2x22 mm]</p> 	<p>4x [3,9x13 mm]</p> 	
<p>2x D4E</p> 	<p>2x D3E</p> 	
<p>D10E</p> 	<p>D9E</p> 	



**IT** Conservare il manuale d'uso per referenze future in prossimità del prodotto. Prima di iniziare l'assemblaggio leggere attentamente le avvertenze. **GB** Keep this instruction manual with the product for future reference. Read the instructions carefully before assembly. **DE** Bewahren Sie das Benutzerhandbuch in der Nähe des Produkts auf, damit Sie später jederzeit nachschlagen können. Lesen Sie vor der Montage die Anweisungen aufmerksam durch. **FR** Conserver le manuel d'utilisation à proximité du produit pour de futures références. Lire attentivement la notice avant de commencer l'assemblage. **ES** Guardar el manual de uso para futuras consultas cerca del producto. Antes de empezar el montaje, lea detenidamente las advertencias. **NL** Bewaar de handleiding in nabijheid van het product voor toekomstige raadpleging. Lees deze voorschriften aandachtig alvorens met de montage te beginnen. **TR** Kılavuzu ileride başlamak üzere ürüne yakın bir yerde saklayın. Montaja başlamadan önce etiketleri dikkatle okuyun. **GR** Φυλάξτε αυτό το εγχειρίδιο χρήσης κοντά στο προϊόν για μελλοντικές χρήσεις. Πριν ξεκινήσετε την συναρμολόγηση διαβάστε προσεκτικά τις προειδοποιήσεις ασφαλείας. **RUS** Храните руководство пользователя поблизости от изделия для дальнейшего к нему обращения. Перед тем, как приступить к сборке, внимательно ознакомьтесь с предупреждениями. **RO** Păstrați manualul de utilizare în apropierea produsului pentru consultări ulterioare. Înainte de a începe asamblarea citiți cu atenție avertismentele. **CZ** Uchovejte tento návod pro jeho případné další použití. Před montáží si pečlivě přečtěte instrukce. **PL** Przechowywać instrukcję obsługi w pobliżu produktu do przyszłych konsultacji. Przed rozpoczęciem montażu przeczytać uważnie pouczenia. **PV** Guardar o manual de uso para consultas futuras na proximidade do produto. Antes de iniciar a montagem, leia os avisos com atenção.

01

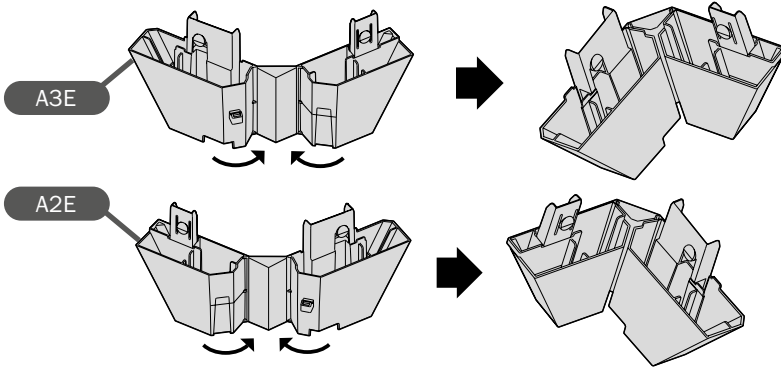

02

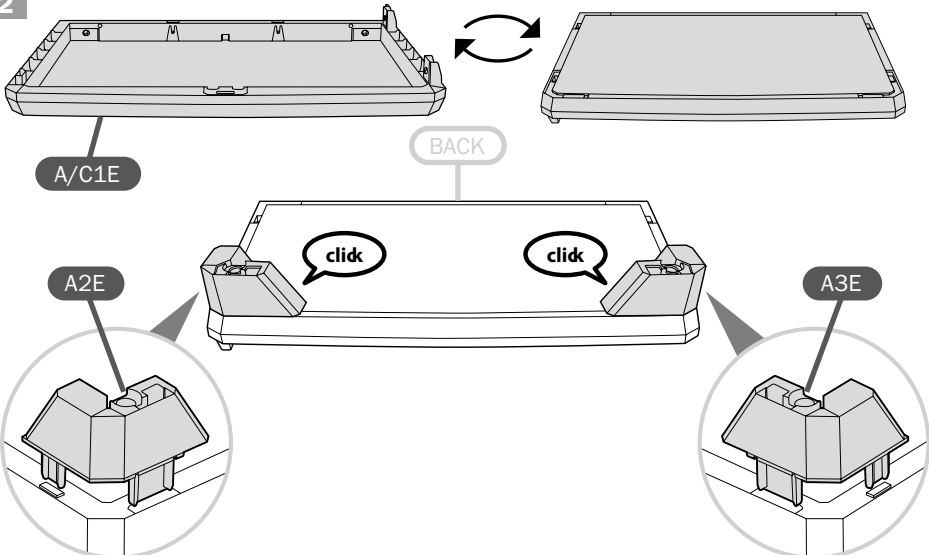

03

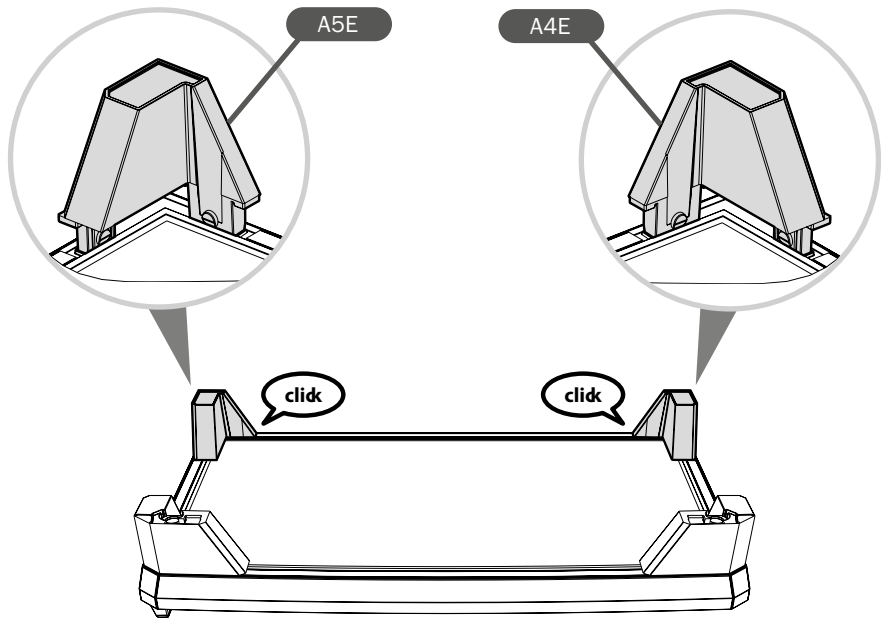

04

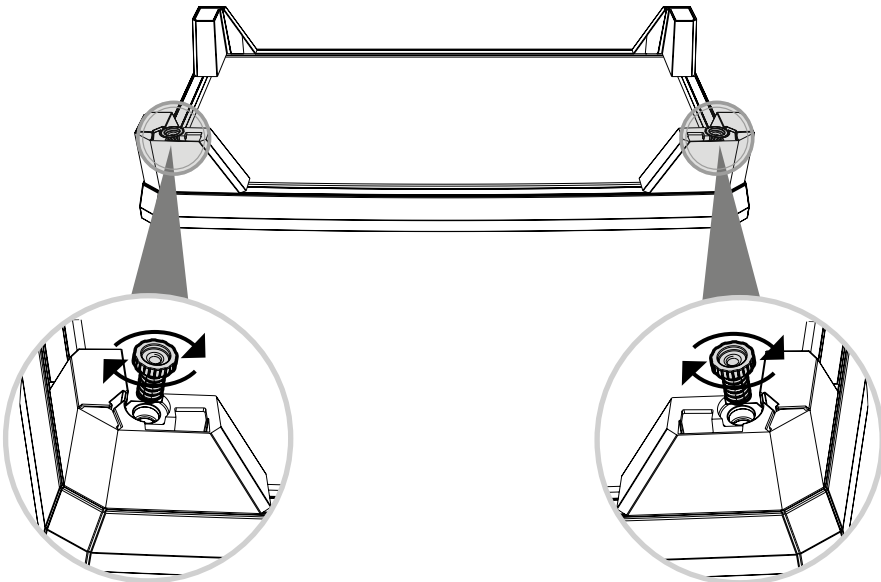



05

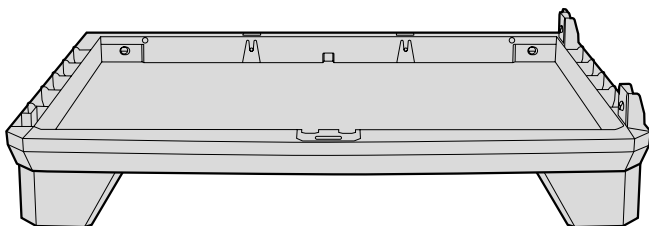
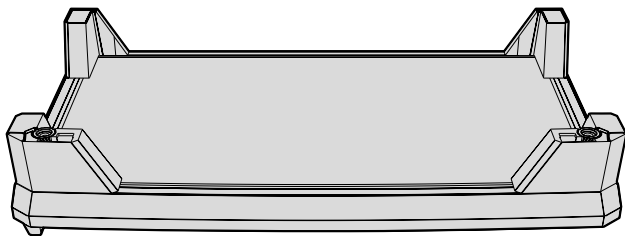

06

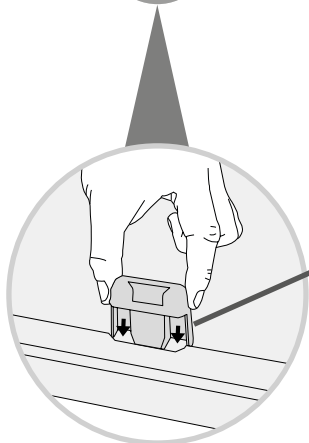
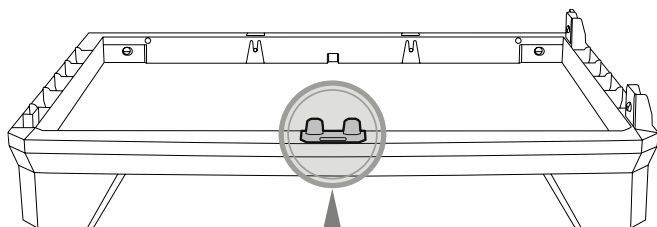

A/C3E

07

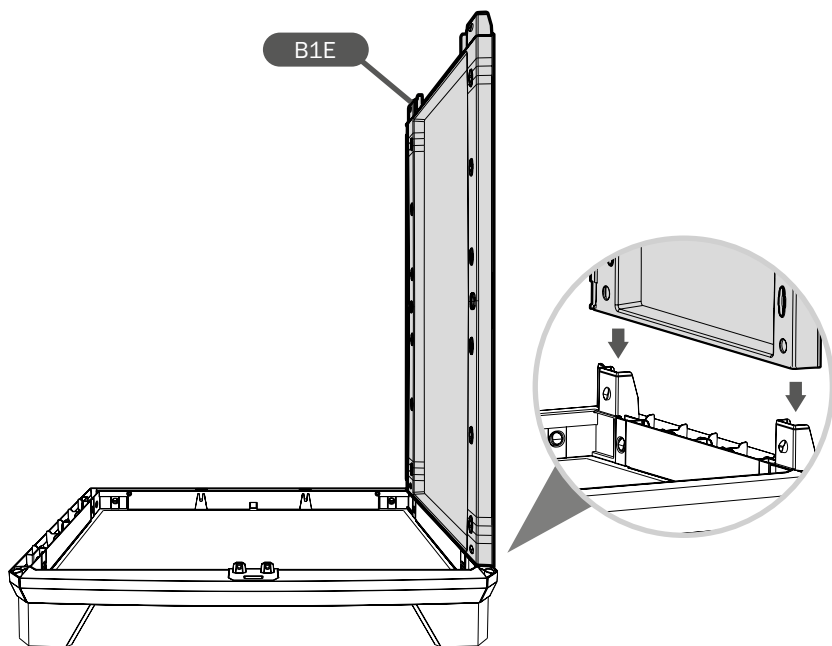

08

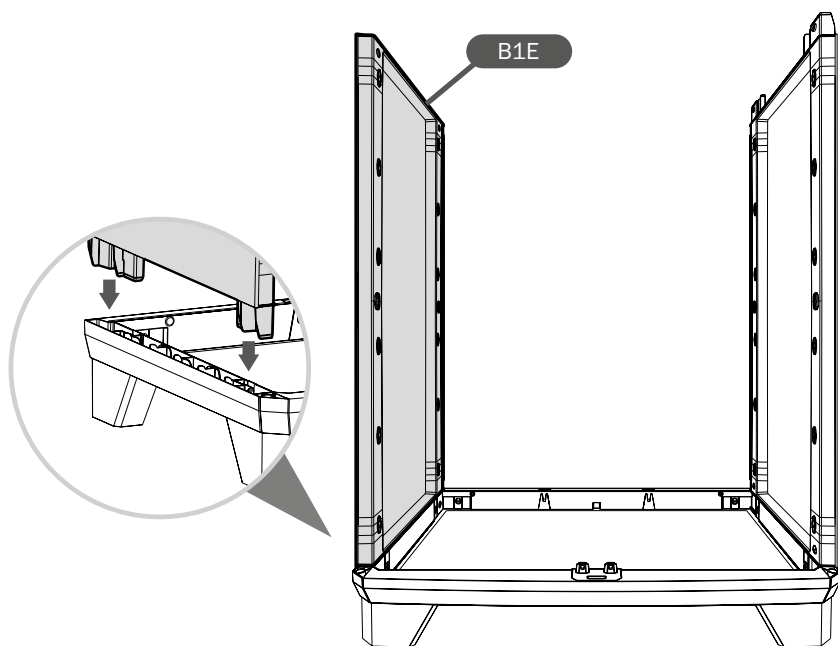

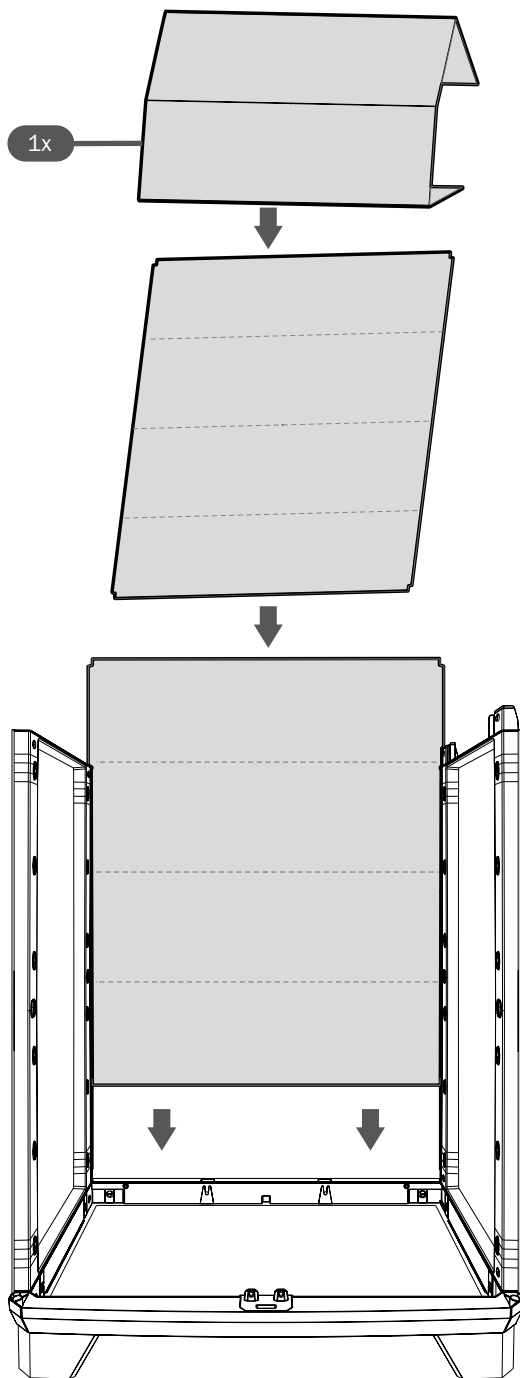

10

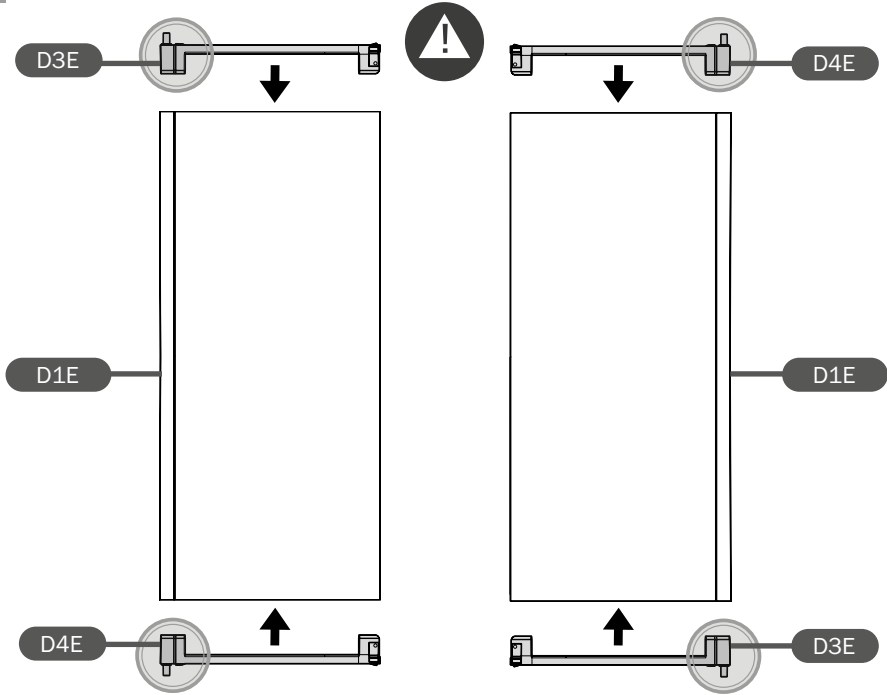

11

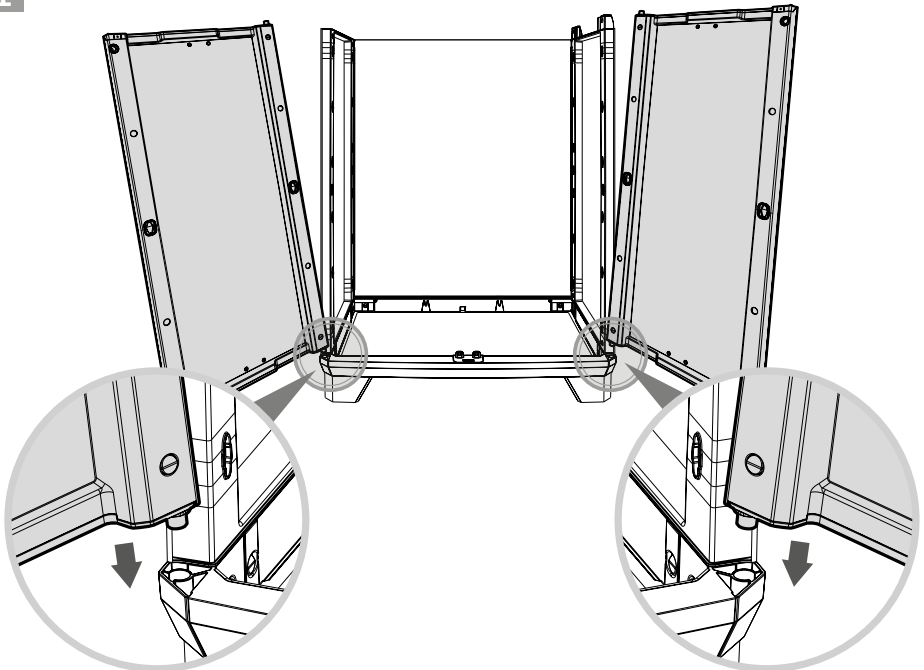

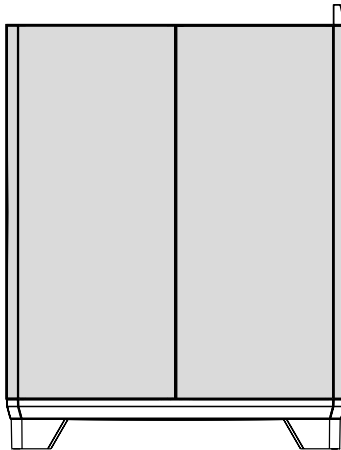
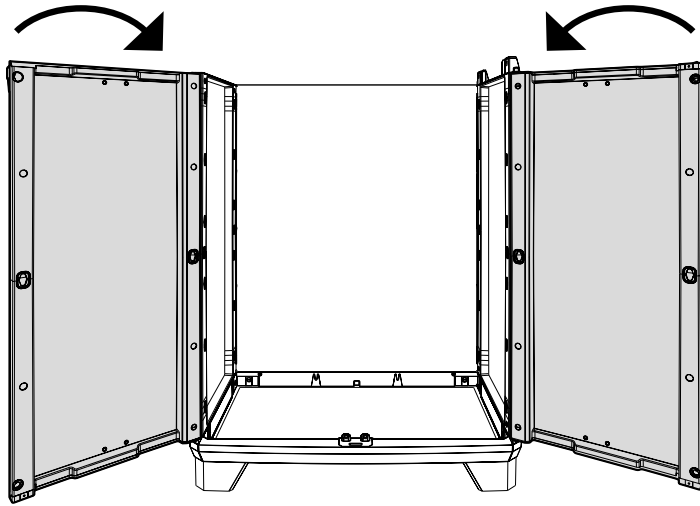

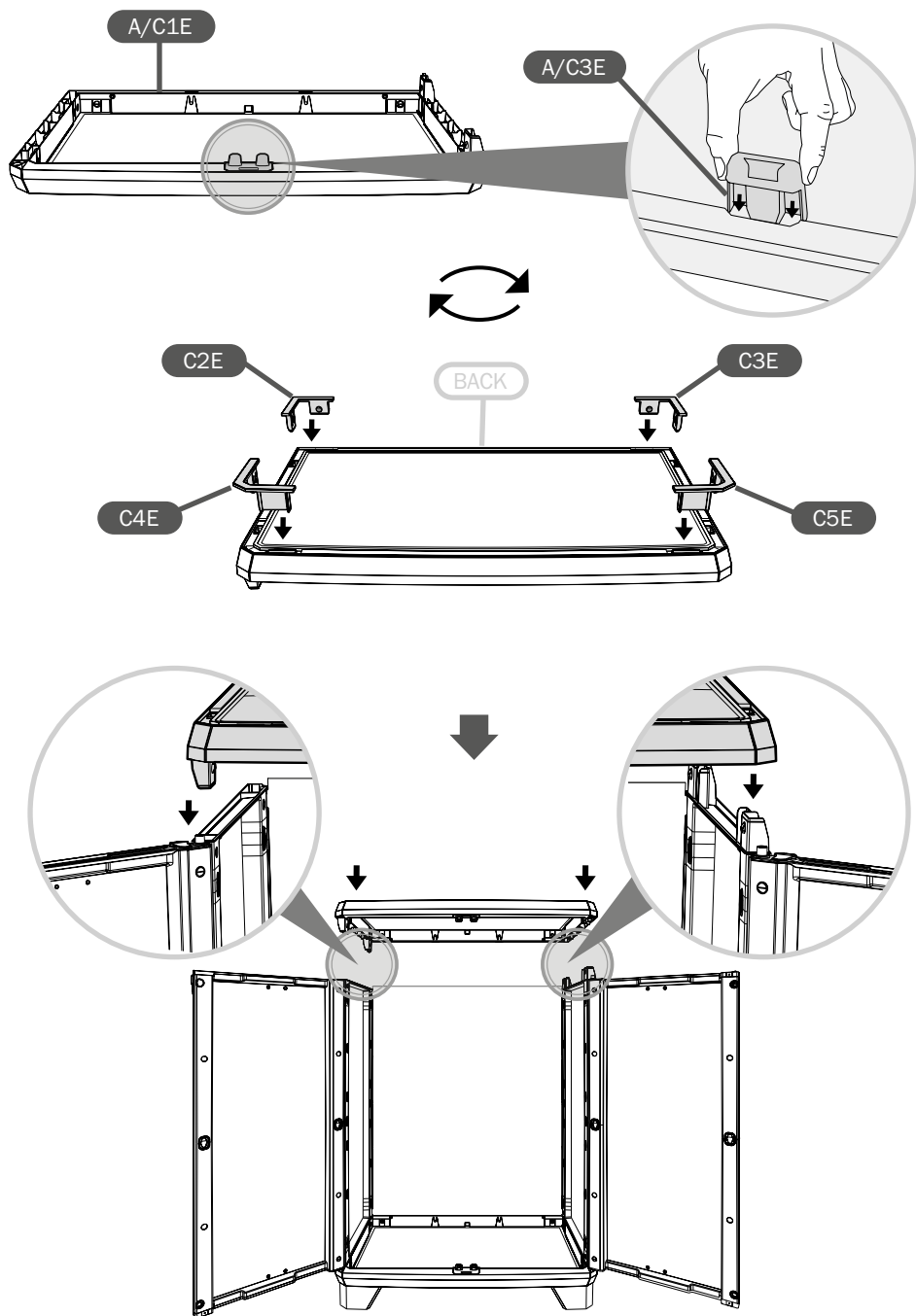

4x [3,9x13 mm]

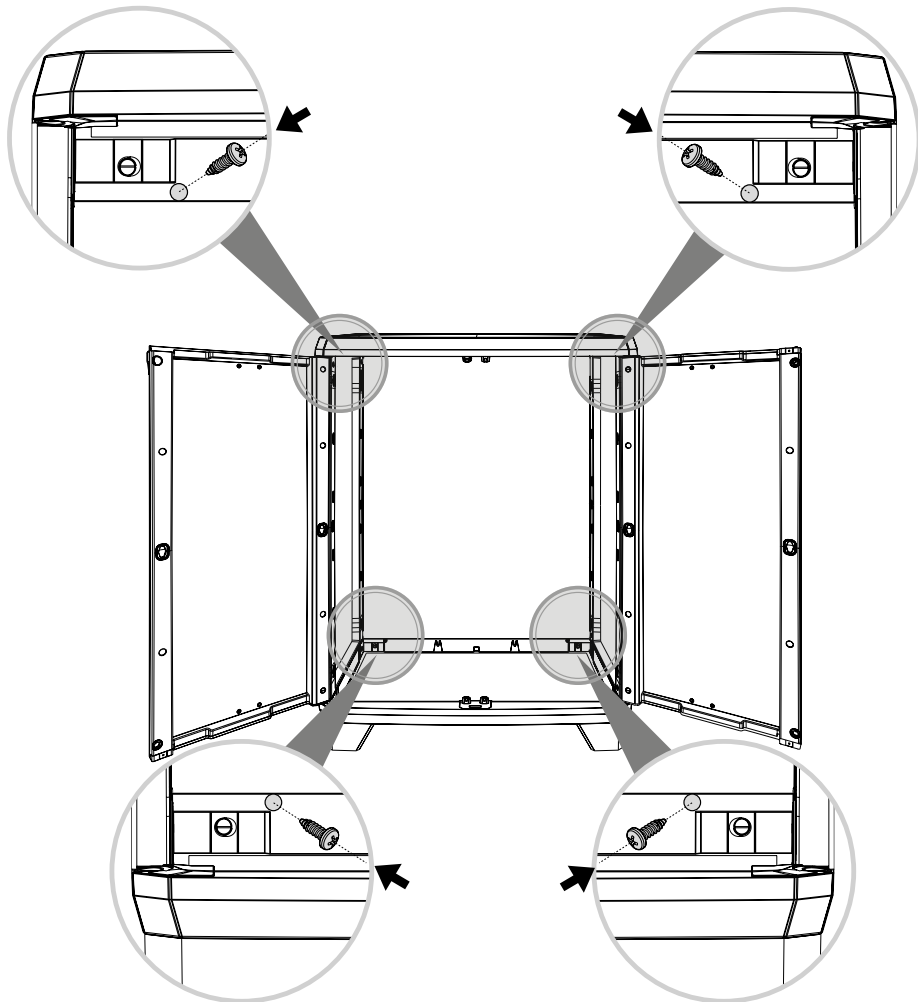
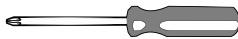

15

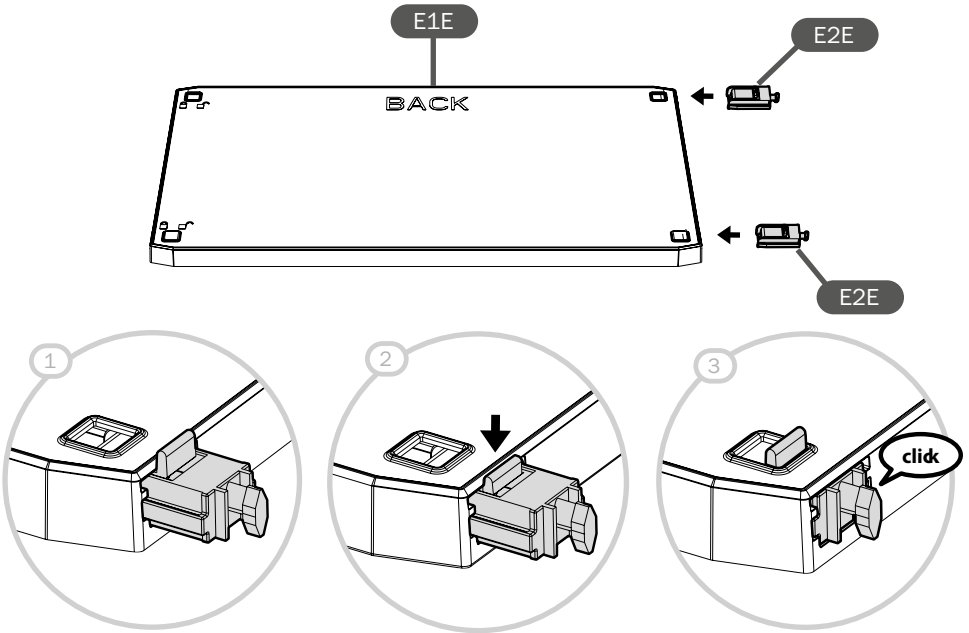

16

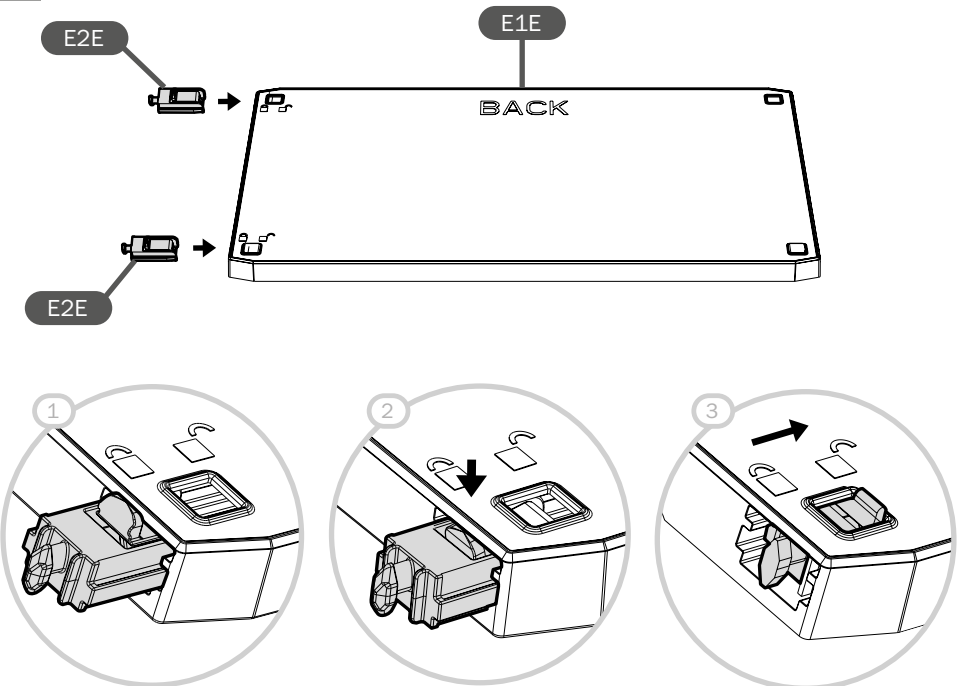



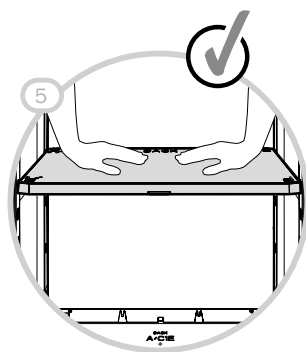
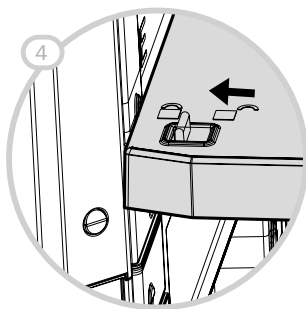
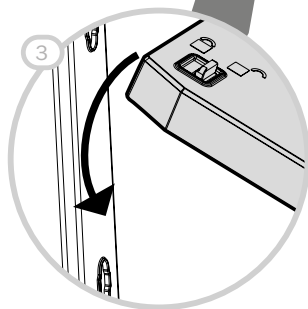
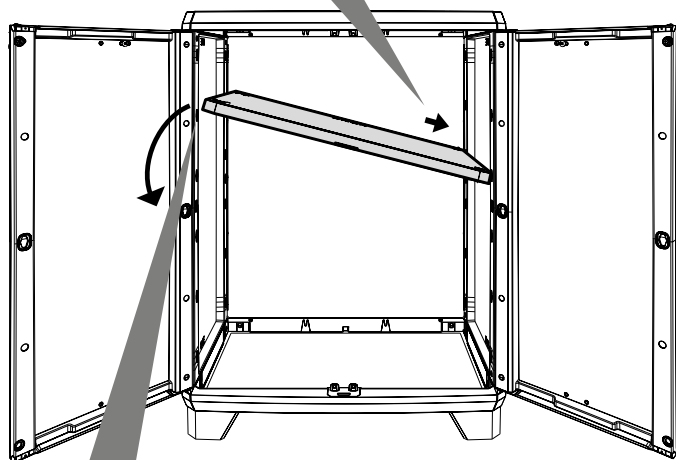
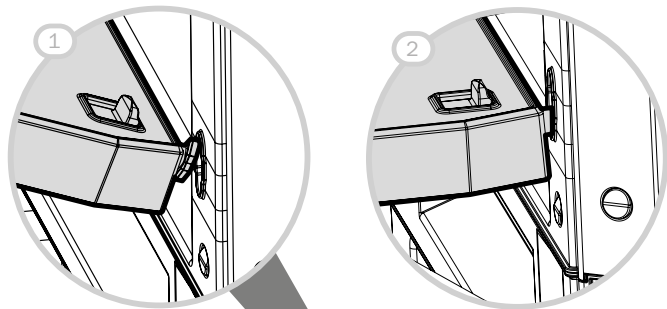

4x [4,2x22 mm]

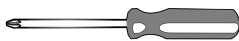

2x

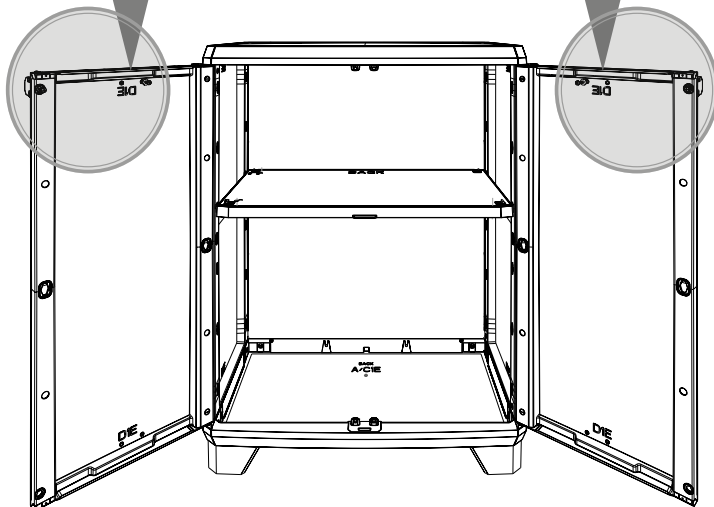
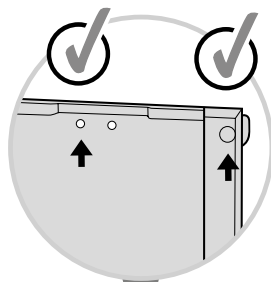
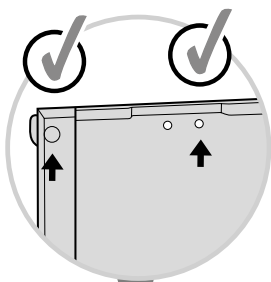
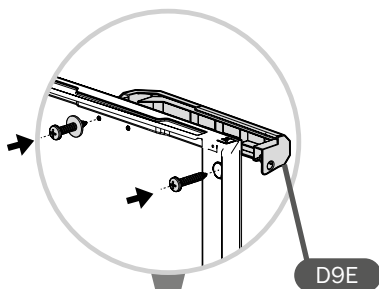
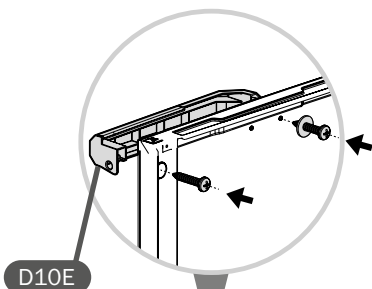

**IT** Per garantire maggiore stabilità dell'armadio su superfici irregolari, utilizzare le viti di regolazione poste sotto i piedi anteriori. **GB** For optimum stability on uneven surfaces, regulate the cupboard using the screws under the front feet. **DE** Um dem Schrank auf unebenen Flächen mehr Stabilität zu verleihen, verwenden Sie bitte die Stellschrauben unter den vorderen Füßen. **FR** Pour garantir une meilleure stabilité de l'armoire sur des surfaces irrégulières, utiliser les vis de réglage placées sous les pieds avant. **ES** Utilice los tornillos de regulación (situados bajo los pies delanteros) para asegurar una mayor estabilidad del armario. **NL** Gebruik de stelschroeven onder de voorpoten om een betere stabiliteit van de kast op onregelmatige vloeren te verzekeren. **TR** Dolabin düzğün olmayan yüzeyler üzerinde daha sağlam bir şekilde durmasını sağlamak için ön ayakların altındaki ayar vidalarını kullanın. **GR** Για να εξασφαλίσετε τη μεγαλύτερη σταθερότητα της ντουλάπας πάνω σε ανώμαλες επιφάνειες, χρησιμοποιήστε τις βίδες ρύθμισης που βρίσκονται κάτω από τα μπροστινά πόδια. **RUS** Для того, чтобы обеспечить наибольшую устойчивость шкафа на неровной поверхности, воспользуйтесь регулировочными винтами, расположенными под передними ножками. **RO** Pentru a garanta o stabilitate mai mare a dulapului pe suprafețele neregulate, utilizați șuruburile de reglare aflate sub picioarele din față. **CZ** Abyste zajistili co největší stabilitu skříně na nerovném povrchu, použijte regulační šrouby umístěné pod předními nožičkami. **PL** Aby zagwarantować większą stabilność szafy, w przypadku nieregularnego podłoża, należy użyć śrub regulacyjnych, znajdujących się pod przednimi nóżkami. **PT** Para garantir maior estabilidade do armário sobre superfícies irregulares, utilize os parafusos de regulação situados em baixo dos pés dianteiros.

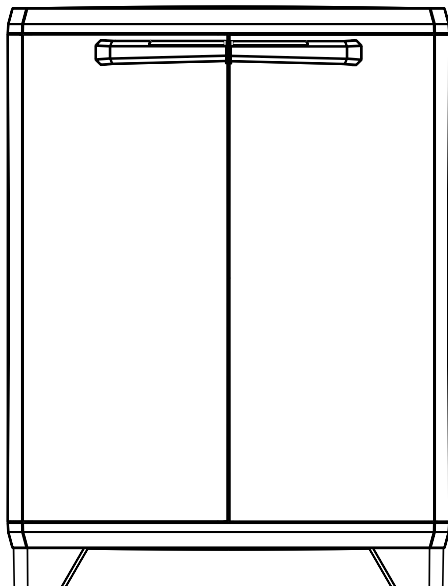

**IT** Fissare l'armadio a muro (viti e tasselli non inclusi). Scegliere il tassello in base alla superficie di appoggio. **GB** Fasten the cupboard to the wall (screws and anchors not included). Choose the anchor according to the surface. **DE** Befestigen Sie den Schrank an der Wand (Schrauben und Dübel sind nicht im Lieferumfang enthalten). Den Dübel je nach Stellfläche wählen. **FR** Fixer l'armoire au mur (vis et chevilles non incluses). Choisir la cheville en fonction de la surface d'appui. **ES** Fije el armario en la pared (la dotación no incluye tornillos y tacos). Elija el taco en función de la superficie de apoyo. **NL** Bevestig de kast aan de muur (schroeven en pluggen niet bijgeleverd). Kies de plug aan de hand van het steunoppervlak. **TR** Dolabı duvara sabitleyin (vidalar ve dübeller dahil değil). Destek yüzeyine göre dübel seçin. **GR** Στερεώστε την ντουλάπα στον τοίχο (βίδες και ούπα δεν περιλαμβάνονται). Επιλέξτε το ούπα ανάλογα με την επιφάνεια στήριξης. **RUS** Закрепите шкаф на стене (шурупы и дюбели не включены в поставку). Возьмите дюбель, пригодный для материала поверхности, у которой ставится шкаф. **RO** Fixați dulapul la perete (șuruburi și dibluri neincluse în dotare). Alegeți diblul în funcție de suprafața pe care urmează să se fixeze. **CZ** Připevňte skříň ke zdi (šrouby a kolkli nejsou součástí dodávky). Zvolte hmoždinku podle povrchu podkladu. **PL** Przymocować szafę do muru (śruby i kolki nie są zawarte w dostawie). Dobrać kolek w zależności od powierzchni oparcia. **PT** Fixe o armário na parede (parafusos e buchas não incluídos). Escolher a bucha conforme a superfície de apoio.

